

/ INSTALLATION INSTRUCTIONS

VANITIES / TALL CABINETS

Before installation read all instructions carefully.

IMPORTANT

All goods must be checked prior to installation. If defects are found due to manufacturing faults then goods **MUST NOT be installed.**

The merchant must inform Bath Co if there is a manufacturing defect and the installation has been carried out. Bath Co will replace the item, however, the installation costs will be the responsibility of the installer. When installing the cabinets – the drawers and doors may need to be adjusted, due to movement throughout carrying the goods. Please view the instructions on the following pages for hinge & drawer adjustments. Any wall to which product is fixed must be of suitable construction to support that product's weight.

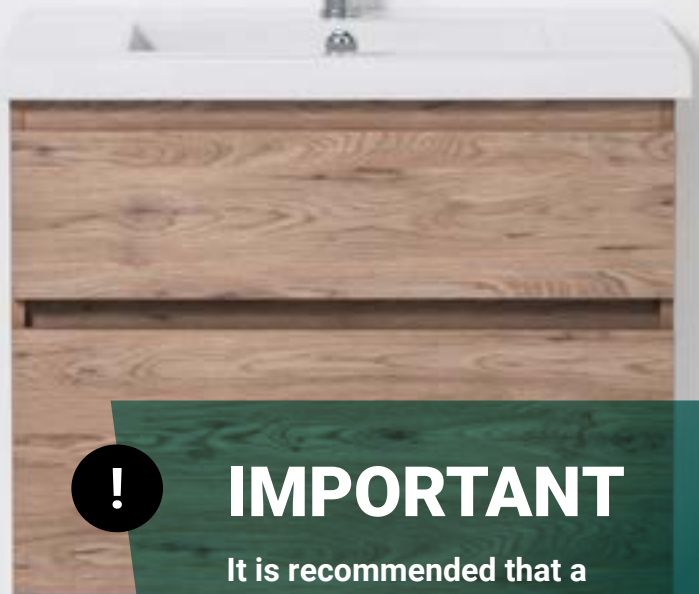

!

IMPORTANT

It is recommended that a qualified, licensed trades person install your unit.

Contents

[pg 2 Vanity Installation](#)

[pg 5 Drawer Installation, Adjustment & Removal](#)

[pg 12 Tall Cabinet Installation](#)

[pg 13 Door Hinge Adjustment](#)

[pg 14 Basic Drawer Adjustments](#)

[pg 15 Waste Installation](#)

[pg 16 Product Care](#)

[pg 17 Trouble Shooting](#)

[pg 18 Warranty Information](#)

/ VANITY INSTALLATION

Please read carefully. It is recommended that a qualified, licenced trades person install your unit.

! IMPORTANT INFO

Tiles/Mirrors etc. Surrounding the installation must provide adequate space for future removal of product if required. Tiles or mirrors must clear cabinet by at least 3mm. **We recommend tiling behind furniture and ceramics.**

Product should not be exposed to direct sunlight or heat-lamps etc as this could cause premature discoloration or fading.

Required Tools & Materials



Spirit level



Caulking gun



Masking tape



Tape measure



Pencil



Silicone sealant



Screwdriver & screws



Drill, hole saw & bits



Cleaning materials

01

Inspect The Unit

Prior to installation it is important to inspect the unit to ensure no damage has occurred in transit. If damage has occurred, or a visible defect exists, do not proceed with installation and advise supplier immediately. **Note: Manufacturer will not be liable for any installation, removal or re-decorating costs. The warranty will be null and void if damage occurred during or after installation.**

IMPORTANT

02

Check The Wall & Floor Is Straight

Check the wall & floor is straight, (not bowed or twisted).
Ensure unit is square against the wall or floor before securing.
Door and drawer alignment could be affected otherwise.

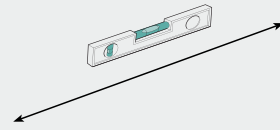

03

Measure Height For Placement

For wall-hung units: Decide appropriate height for top of unit, about 900mm from floor. Measure the distance from top of unit to top of solid back (allowing for the top), e.g. if distance from top to solid back is X mm, measure X mm down from the recommended 900mm.

For tall cabinets and utility cabinets with a hanging rail:

Measure from top of unit to bottom of fixing rail. Mark distance on wall as mentioned for solid back units. Fix bottom of hanging rail above mark.

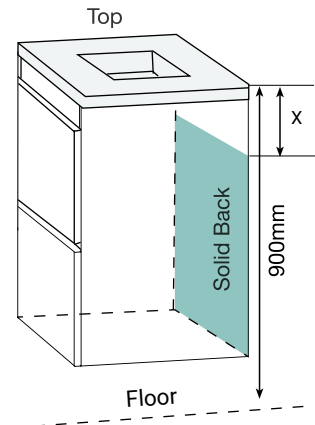

04

Drill Holes For Pipes & Check Placement

Drill holes for pipes in base/rear of unit with appropriate size hole saws. Position plumbing and holes as high as possible to allow for drawer clearance.

Position unit over pipes in correct position. Check level with a spirit level.

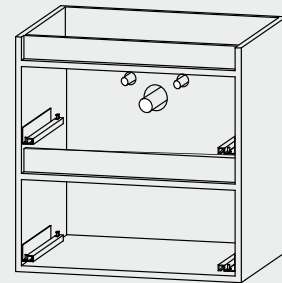

06

Fasten Unit To Wall

Securely fasten unit through the back into a solid fixing (dwang or stud), no further than 100mm from end of cabinet. Upper fixings no lower than 50mm from top of back.

It is a preferable to fasten the cabinet through the steel bracket in the top corner of unit (pictured).

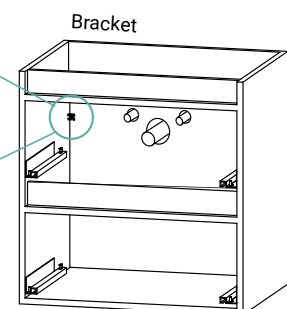
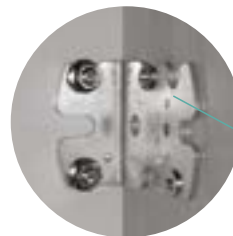

08

Secure The Top

Tops with allowance for bolts must be fixed to a solid fixing in a wall through the bolt holes with supplied bolts. Tops without fixing holes should be secured with silicone only. As ceramic tops are not perfectly flat (may vary up to 5mm), due to the manufacturing process, it may be necessary to pack the tops up to stop movement or avoid the doors or drawers binding. Up to a 5mm tolerance is acceptable.

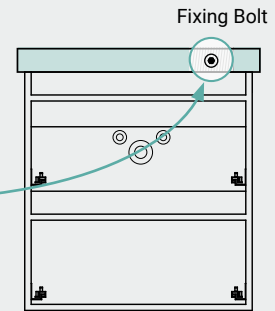
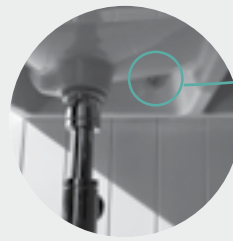

09

Seal Edges

Seal all edges where water penetration may occur, i.e. between top, wall and floor etc. (Materials used in the construction of bathroom furniture are water-resistant not waterproof). Ensure silicone is used according to manufacturers' instructions. **DO NOT use adhesive, this will void warranty.**

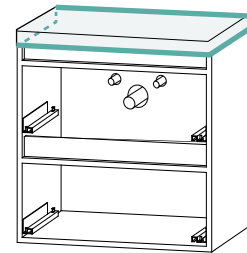

10

Fit Counter Top And Semi-Recessed Basins

Where a separate basin is to be fitted it is essential that the basin must be centered over the cutout and be fully sealed to the cabinet and top to prevent any water penetration.

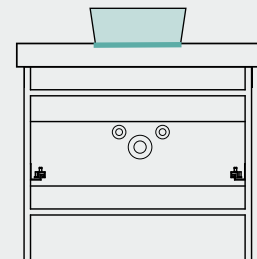

11

Fitting The Waste

When fitting the waste use the washers supplied. If sealing the underside please use plumbers putty only (**do not use silicone**) and do not over-tighten as it can cause the basin to crack. Make sure no excess putty obstructs the water flow including the overflow.



See Pg 15 For Installation Instructions

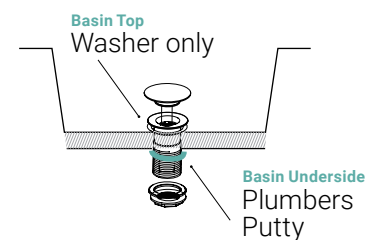

12

Drawer & Door Adjustment

Adjust doors/drawers if required, as there may have been some movement during transportation or installation, (**refer to drawer & hinge adjustments on page 5**). However, first check that the unit has not been twisted during installation.

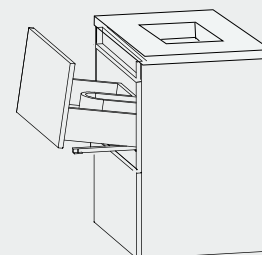

/ DRAWER ADJUSTMENT

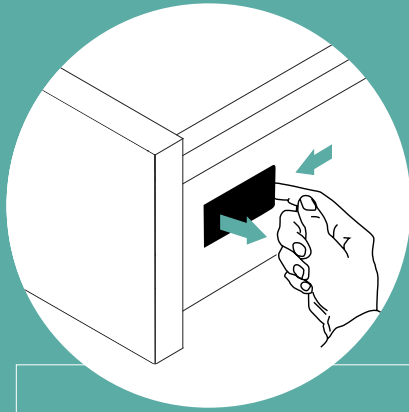

How to Identify Your Drawer Style?

Unclip cover to see which mechanism underneath to match to corresponding diagram below.

Magic Box

Instructions found on page 6 & 7

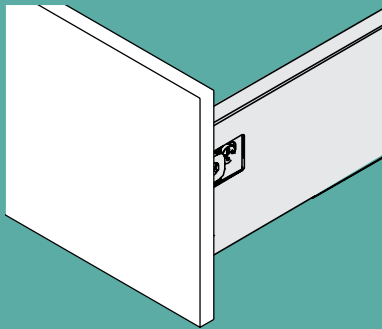

Harn Drawers

Instructions found on page 8 & 9

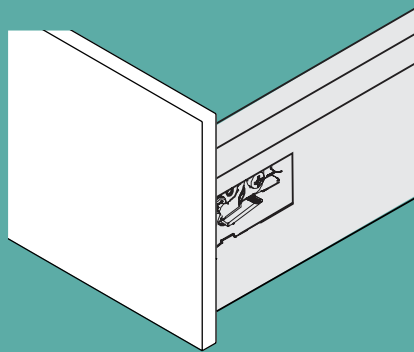

DTC Drawers

Instructions found on page 10 & 11

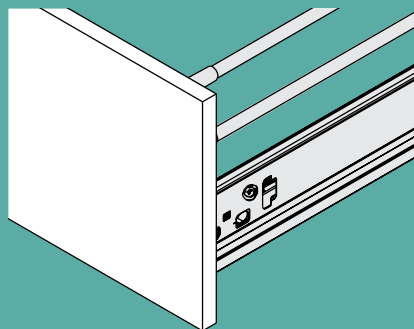

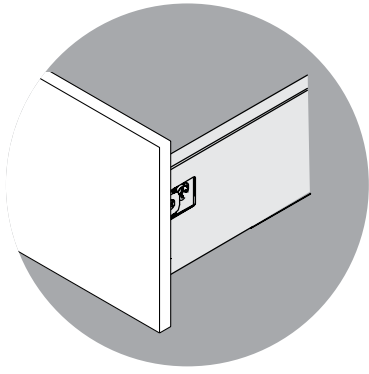

Magic Box Drawer Adjustment

Remove Cover

Unclip cover on both sides of drawer

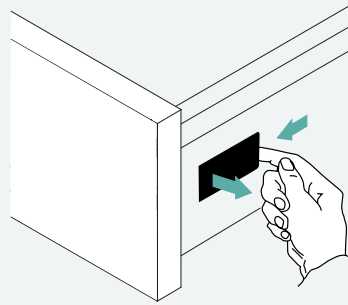

Left/Right Adjustment

You can adjust the drawer left or right by turning the front screw clockwise or counter clockwise to the desired position.

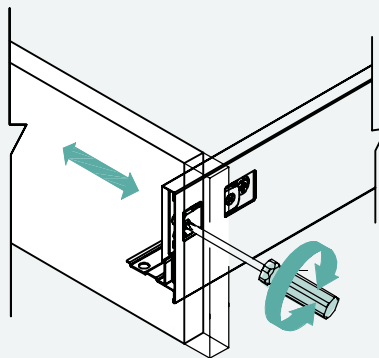

Up/Down Adjustment

To adjust the doors up or down, turn the back screw clockwise or counter clockwise to the desired position.

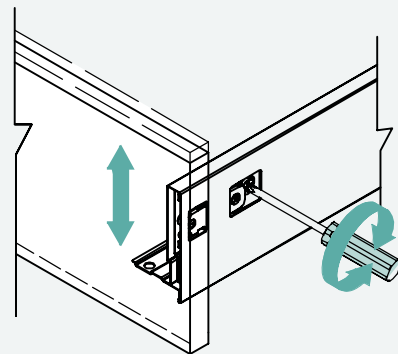

In/Out Adjustment

You can adjust the drawer front in or out by pushing or pulling the lever at both sides of the bottom of the drawer.

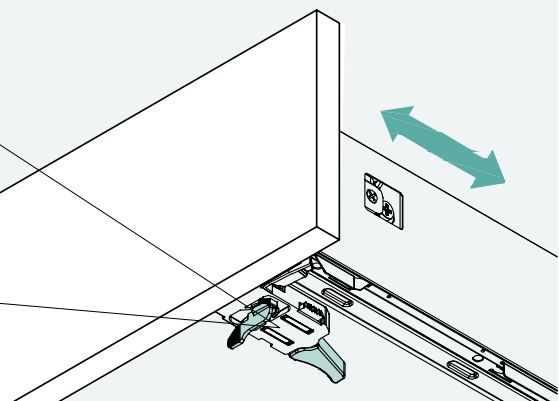
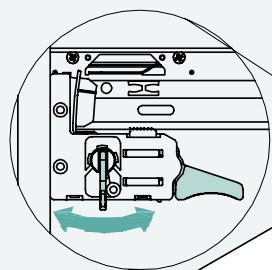

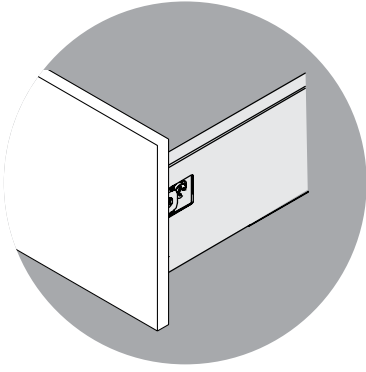

Magic Box Drawer Removal

Drawer Box Removal

1. Press in the lever on either side of the bottom of the drawer.
2. Pull the drawer out fully.

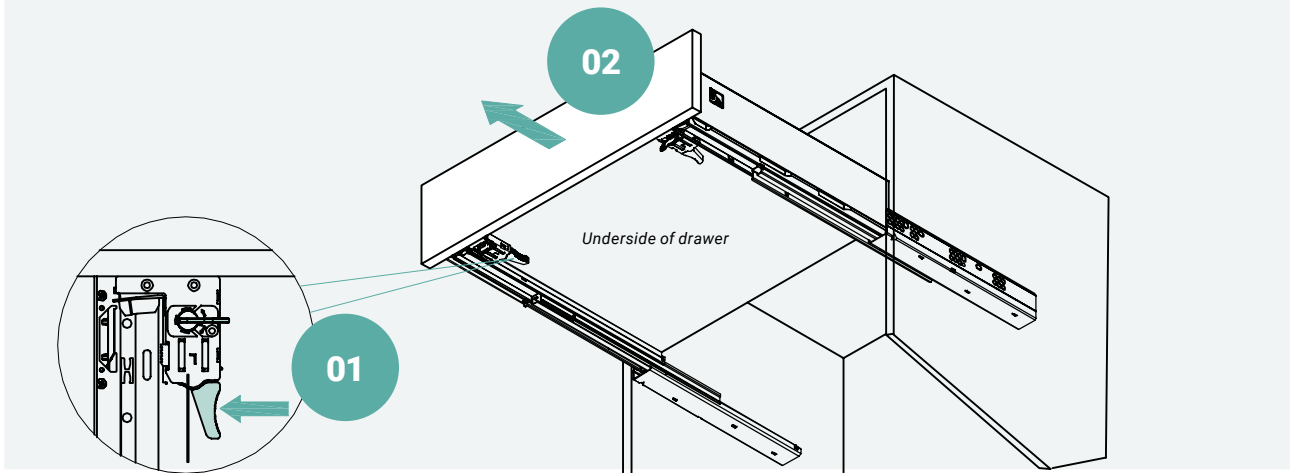

! When reinstalling, push the drawer fully in to engage the soft close mechanism.

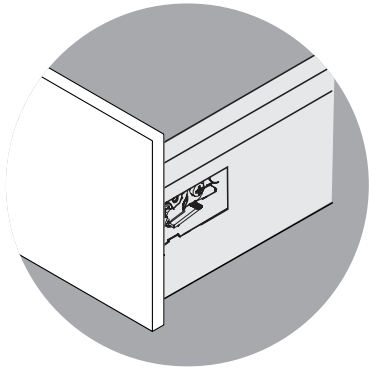

Horn Drawer Adjustment

Remove Cover

Unclip cover on both sides of drawer

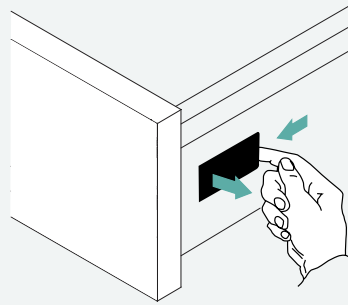

Left/Right Adjustment

You can adjust the drawer left or right by turning the front screw clockwise or counter clockwise to the desired position.

To Right

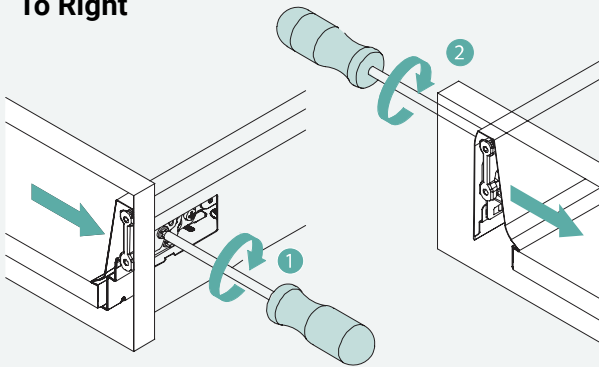

To Left

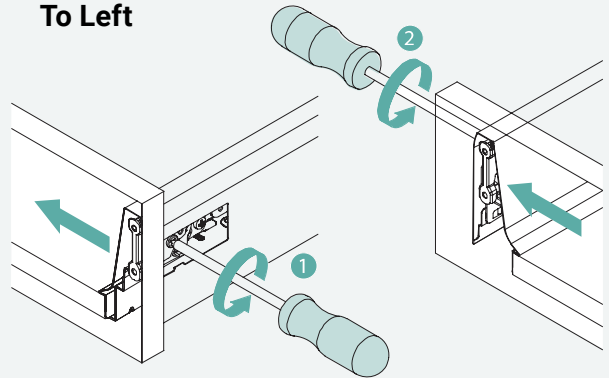

Up/Down Adjustment

To adjust the doors up or down, turn the back screw counter clockwise to loosen. Adjust front panel, then re-tighten back screw.

1. Loosen

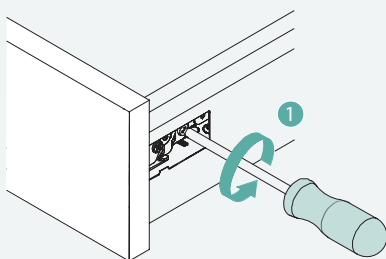

2. Move Up or Down

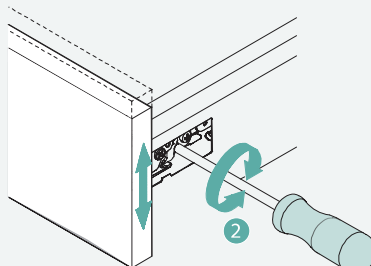

3. Tighten

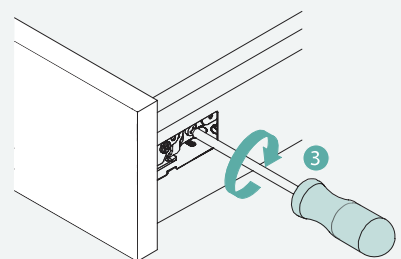

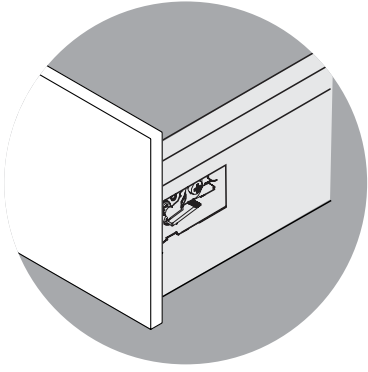

Harn Drawer Removal

Drawer Removal

Slide drawer out and lift up and off the runners

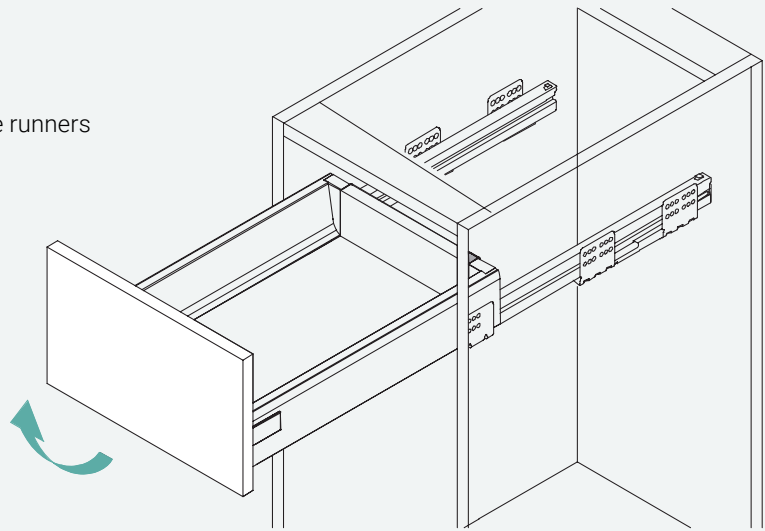

! When reinstalling, push the drawer fully in to engage the soft close mechanism.

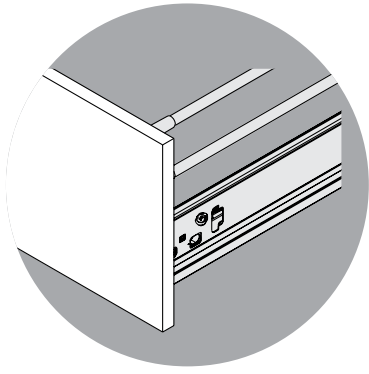

DTC Drawer Adjustment

Remove Cover

Unclip cover on both sides of drawer

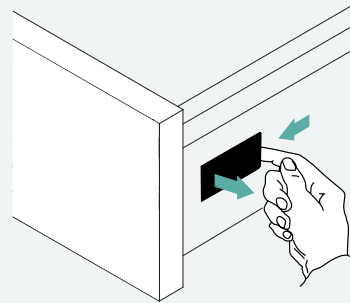

Left/Right Adjustment

You can adjust the drawer left or right by turning the front screw clockwise or counter clockwise to the desired position.

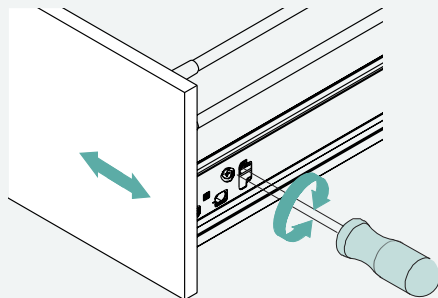

Up/Down Adjustment

To adjust the doors up or down, turn the back screw clockwise or counter clockwise to the desired position.

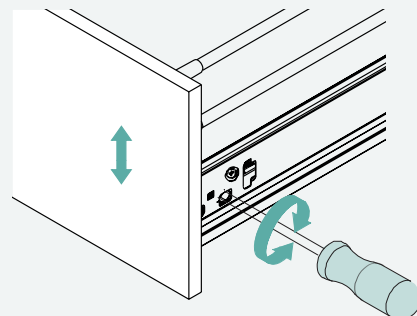

In/Out Adjustment

You can adjust the drawer front in or out by pushing or pulling the lever at both sides of the bottom of the drawer.

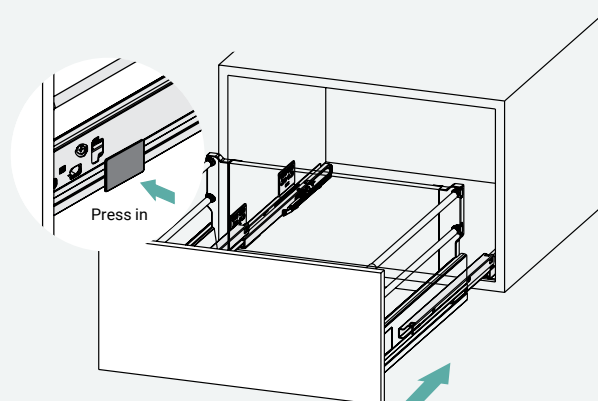

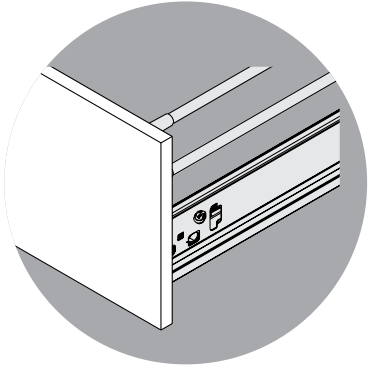

DTC Drawer Removal

Remove Cover

Unclip cover on both sides of drawer

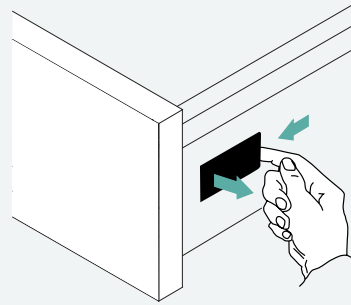

Drawer Removal

1. Lift the release handle and pull out the drawer.

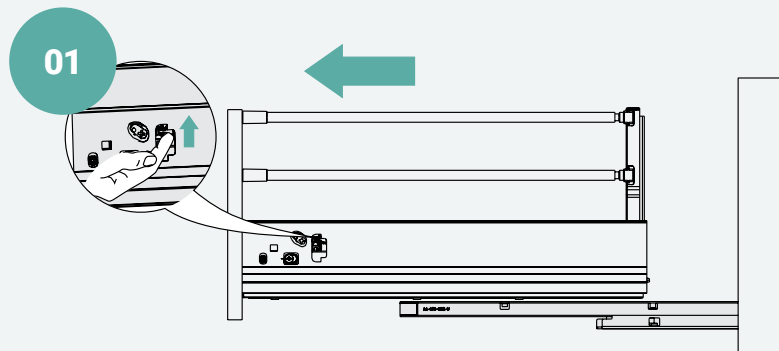

! When reinstalling, push the drawer fully in to engage the soft close mechanism.

/ TALL / UTILITY CABINET INSTALLATION

It is the responsibility of the qualified installer to make any adjustments to align doors and drawers after installation if required.

01

Prepare

Remove all unfixed internal shelves or drawers

Check the wall is straight

02

Measure

Measure desired height for placement and mark the position of the top of the cabinet

Check that the unit is level

03

Install

Secure unit to wall through back. Align fixings with dwangs or studs

Reinstall shelves and drawers

04

Adjust

Adjust door or drawers if needed.
(Door adjustments shown on page 13 and basic steel runner drawers as used in tall cupboards are on page 14).



/ DOOR HINGE ADJUSTMENT

It is the responsibility of the qualified installer to make any adjustments to align doors and drawers after installation if required.

Note: All fittings have been factory set and should not need adjustment. Check that the unit has not been twisted during installation before making adjustments.

Left/Right Adjustment

You can adjust the doors left and right by turning the front screw clockwise or counterclockwise to the desired position.

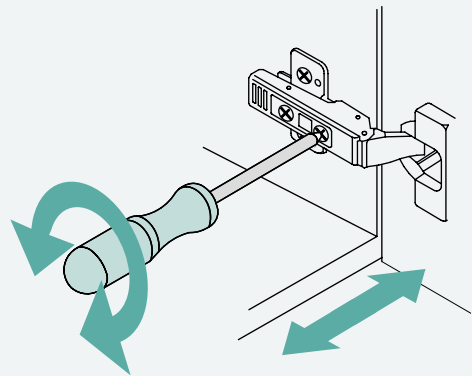

Up/Down Adjustment

To adjust the doors up or down, loosen the two screws on both sets of door hinges and lift the door to the desired height and re-tighten.

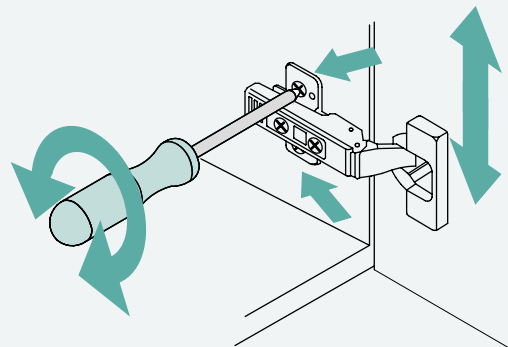

In/Out Adjustment

When adjusting doors in or out, loosen the rear screw and slide the door into desired position before tightening it.

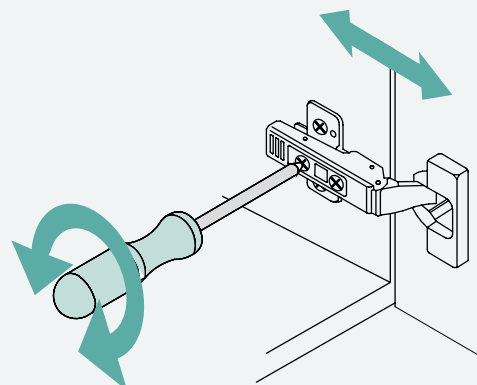

/ BASIC DRAWER ADJUSTMENT

It is the responsibility of the qualified installer to make any adjustments to align doors after installation if required.

Drawer Front Left/Right Adjustment

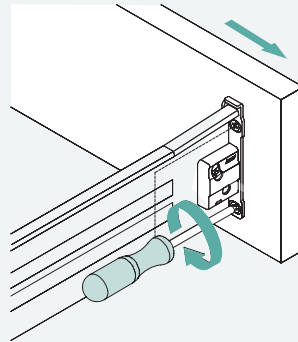
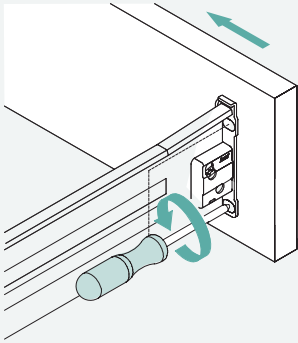

Drawer Front Up/Down Adjustment

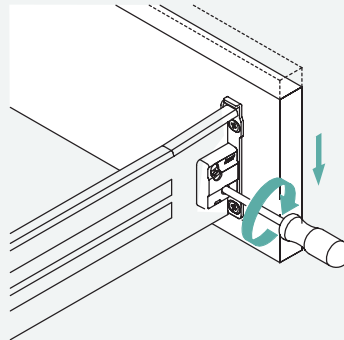
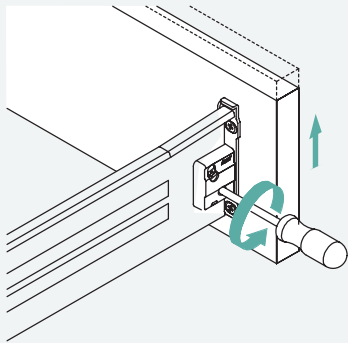

Drawer Removal

Slide drawer out and lift up and off the runners

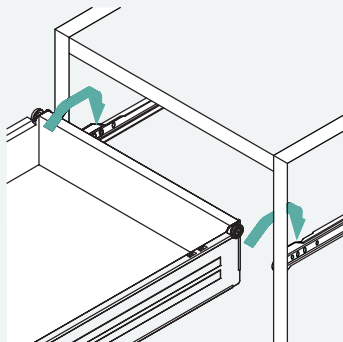

Drawer Insertion

Slide drawer in, making sure the roller on the drawer fits into the drawer cabinet channel.

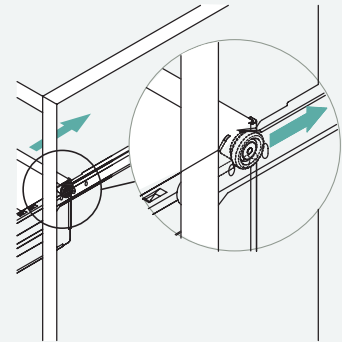

/ CONTOURED POP-UP WASTE INSTALLATION INSTRUCTION

SKU: PUW68R (with overflow) | W22 NEW VERSION (with out overflow)



A contoured waste has a bevelled edge on the chrome flange of the waste and a Washer installed either side to help Prevent it from coming into contact with the porcelain and cracking the basin.

DO NOT OVER TIGHTEN - HAND TIGHTEN ONLY

USE CONTOURED WASHER PROVIDED
DO NOT REPLACE WITH SILICONE
 THE USE OF SILICONE WILL
 VOID THE VANITY WARRANTY

IMPORTANT

- Please check this product immediately to ensure that it has not been damaged and is complete. Before installation, please make sure this product is the correct model and you have all the parts required for installation and using.
- Please read these instructions carefully and keep it for future reference.

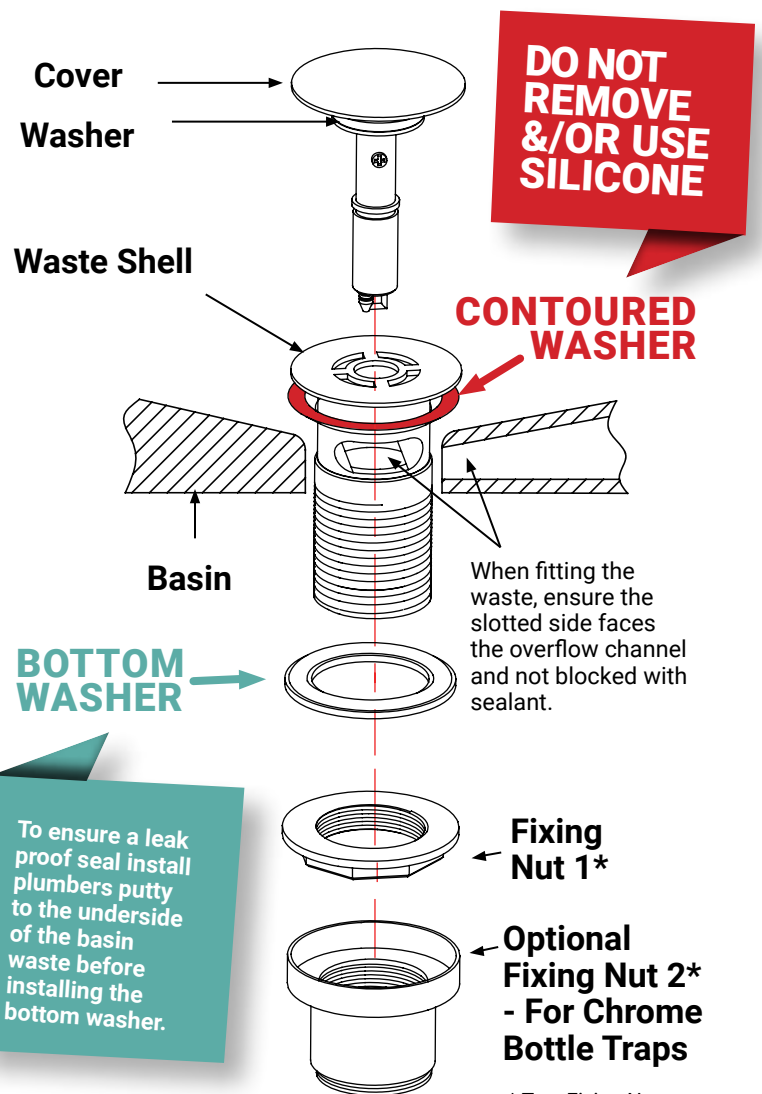

* Two Fixing Nuts are supplied for your selection.

/ PRODUCT CARE

General Cleaning

Bath Co products are made from materials or sourced specifically for bathroom and laundry spaces. Our vanities and cabinetry are designed to be water resistant, not waterproof. Care must be taken to immediately dry spillage as well as ventilate your bathroom to eliminate moisture build up or humidity which will lead to deterioration of materials and is not covered by warranty.

For all surfaces use a soft cloth and a weak solution of a non-abrasive detergent. Do not use cleaners with isopropyl alcohol, high alkaline, acidic or any abrasive based cleaners. A moist microfibre cloth will give the best results.

Cabinetry Finishes

Timber Veneer & Painted To clean Bath Co timber veneer surfaces simply use a soft cloth and a weak solution of a non-abrasive detergent. Do not use cleaners with isopropyl alcohol, high alkaline, acidic or any abrasive based cleaners.

Melamine Melamine is low maintenance and easy to clean. Simply wipe down with a clean, damp cloth. With stubborn grease and grime, use vinegar diluted with water or Selseys Sugar Soap. Always wipe with a damp cloth, then a dry cloth after cleaning to remove moisture. Never use abrasive cleaners, cleaners with isopropyl alcohol, high alkaline, acidic or any abrasive based cleaners.

Basins & Counter Top Vessels

China/Acrylic/Polymarble To clean acrylic surfaces use non-abrasive soap, eg: Spray n' Wipe, Mr Muscle (non-citrus based) and water. It is recommended that the product surface is wiped dry after each use to prevent the build up of soap and scum.

Kordura Please refer to Kordura finish cleaning instructions in our resource section on our website www.bathco.co.nz/downloads/product-info-installation

Mirrors

Keep your bathroom well ventilated to avoid condensation that can gather at the edges of your mirror. Always protect from excessive moisture and ensure any moisture or condensation is wiped away immediately.

Wipe your mirrors with a slightly moist microfibre cloth and then dry with a dry microfibre cloth. DO NOT use any ammonia-based cleaning products (including glass cleaners), as these could corrode the mirror's silver backing.







[View our complete care guide here](#)

/ TROUBLE SHOOTING & COMMON QUESTIONS

Problem	Solution
My product is damaged, should I install it?	No , please contact the merchant you purchased your product from immediately
My drawers or doors are not closing correctly	Please refer to drawer adjustments on page 5 to 11 of door adjustments on page 13
Where can I find the dimensions and specifications?	Our specifications are found on our product pages on our website www.bathco.co.nz
What should I clean my product with?	View our Product Care info on page 15 or download our comprehensive guide from our website www.bathco.co.nz/downloads/product-info-installation
What happens if I need spare parts?	Please contact the merchant you purchased your product from
Does it come with a warranty?	Yes, please view our warranties information on page 17 or online www.bathco.co.nz/warranties
How long is my warranty for?	Our warranties differ please view our warranties information online www.bathco.co.nz/warranties
How do I make a warranty claim?	Please contact the merchant your purchased from.

/ WARRANTIES

Residential Warranty Periods

 <p>1 YEAR WARRANTY</p>	 <p>5 YEAR WARRANTY</p>	 <p>15 YEAR WARRANTY</p>	 <p><i>Burlington</i> EXTENDED GUARANTEE</p>
<p>Shower Hoses Shower Heads Cartridges Mirrors Cistern Fittings Wastes Toilet Seats Electrical Face Plates Washers Valves Shower Seals</p>	<p>Vanities & Cabinetry Basins Tops Baths Toilets Showers Tapware</p>	<p>In-Wall Cisterns (Excluding items listed previously)</p>	<p>Extended guarantees are available on Burlington products directly from the manufacturer, Bathrooms Brand Group (English Classic vanities and in-wall cisterns are not applicable).</p>

Commercial Warranty Period

In relation to any Bath Co products installed in a commercial situation a 12 month warranty applies from the date of purchase. Commercial situations are defined as public washrooms, public buildings, schools, sports centres, gymnasium, hospitals, motels, hotels and retirement villages.



[View our full warranty terms here](#)

Terms & Conditions

Bath Co warranties apply to products supplied to customers in New Zealand. Subject to the warranty conditions, in addition to any other right or remedy that the purchaser may have under any relevant consumer protection legislation, Smail & Co undertakes to either repair or replace (at its discretion) any Bath Co product if that product contains a material defect with either materials or workmanship which arose in the course of manufacture.

Bath Co's domestic/residential warranty and commercial warranty is subject to the following conditions:

Proof of purchase (such as invoice or receipt) must be provided by the initial purchaser. This warranty is not transferable.

All Bath Co installation instructions must have been strictly followed and the product must have been installed in accordance with the relevant New Zealand Building/Plumbing Codes by a certified building or plumbing practitioner (as appropriate for the product).

The product must not have been subject to excessive

wear and tear. The warranty only covers normal use and typical wear and tear.

The product must not have been tampered with or repaired in any way other than in accordance with this warranty.

The product must not have been damaged by misuse, accident or neglect, including water damage, sunlight, excessive water temperature, humidity, direct lighting or other adverse environmental conditions.

Harsh detergents or abrasive cleaners must not have been used on the product and the product must be cleaned in accordance with the recommended

cleaning methods.

All warranty covered repair work is to be performed by Bath Co but Bath Co shall not be responsible for the cost of removal or installation of the product.

Bath Co shall make the final determination on any issue or uncertainty regarding the application of this warranty.

If you acquired the Bath Co product in trade (or some other exception exists under the Consumer Guarantees Act 1993 (the Act) then the Act shall not apply.