

# Trent

# Burlington®

## DESCRIPTION

Trent Thermostatic Shower with 6" or 9" Shower Head

## PRODUCT CODE

TF3S / V16 / V17



## FEATURES

- Dimensions - W350 x H95 x D138 mm
- Trent Thermostatic Two Outlet Concealed Shower Valve, Fixed Shower Arm, Handset & Holder with Hose with 6" or 9" Shower Head
- Traditional brass faceplate, Claremont handle, with ceramic levers
- Wall outlet, and 1500mm shower hose
- Adjustable wall bracket, and handset with ceramic handle
- 390mm adjustable fixed shower arm
- The shower head has anti-limescale silicon nipples.
- The length of the shower hose is 1.5m
- Large bore shower hose (11mm)
- Hot & cold inlet 3/4 female thread

## NOTES

Please see next page for technical drawings.

\*Non-stock item. Excludes accessories.

**MICHEL CÉSAR**  
**VCBC**  
**BURLINGTON**  
**LAUNDRY**

/ WHERE BATHROOMS  
& LAUNDRIES  
COME TOGETHER  
BEAUTIFULLY /

info@smail.co.nz  
bathco.co.nz

4-8 Ace Place  
Kingsland  
Auckland 1021  
New Zealand

P +64 9 309 9109  
F +64 9 309 9343

86 Wigram Road  
P.O. Box 8644  
Christchurch 8025  
New Zealand

P +64 3 343 0969  
F +64 3 343 0967

**BATH/**  
**CO/**

# Trent

# Burlington®

## DESCRIPTION

Trent Thermostatic Shower with 6" or 9" Shower Head

PRODUCT CODE

TF3S / V16 / V17

## TECHNICAL DRAWINGS

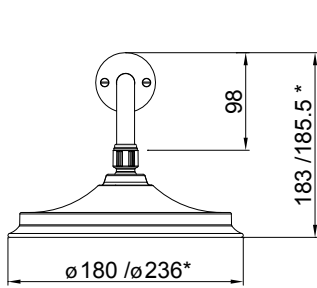

\* Two options of shower heads (6 inch or 9 inch)

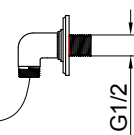
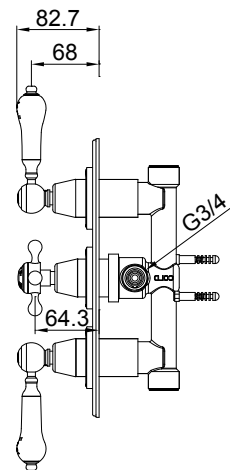
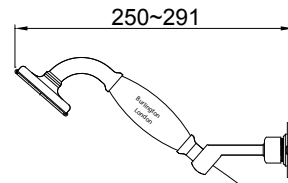
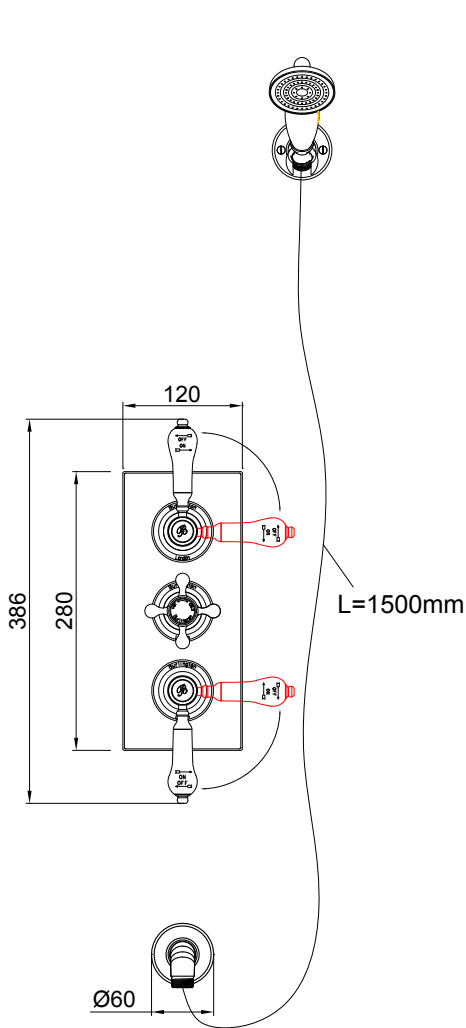
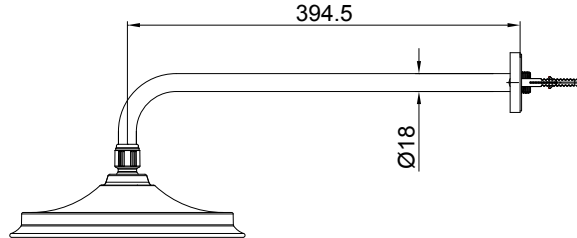

## NOTES

Drawing indicates the technical measurement only and is not a reflection of how the unit will look. Sizes are nominal only. All drawings in millimeters. Drawings not to scale.