

# Space /

vcbc

## DESCRIPTION

Space Floor-Standing Vanity

## PRODUCT CODE

SPA500W  
/ SPA500M



## FEATURES

- Dimensions - W 530 x H 900 x D 250 mm
- Ceramic basin with compact cabinet design.
- One door floor-standing vanity with chrome bar handle.
- Side-mounted tap (tap hole available on right side only)
- Available in White Paint or Timber Effect Melamine finishes.
- The paint used on our products is polyurethane or UV based. Each panel is painted and heated at least five times for a harder, more durable finish than lacquer painted surfaces.
- Timber Effect Melamine is a low-pressure laminate.
- Made in New Zealand.

## FINISHES

Timber Effect Melamine / White Gloss Paint

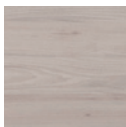

Driftwood

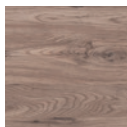

French Oak



Honey Ash



Classic Walnut



Original Oak



Smoked Ash



Southern Oak



Hickory Walnut

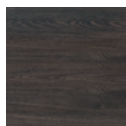

Black Forest

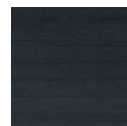

Charred Oak



Nordic Ash



White Gloss

Please see reverse for technical drawings and measurements.

## NOTES

See our website for product prices. Drawing indicates the technical measurement only and is not a reflection of how the product will look. Sizes are nominal only. All drawings in millimeters. Drawings not to scale. 2023.

## DESCRIPTION

Space Floor-Standing Vanity

## PRODUCT CODE

SPA500  
/ SPA500M

## TECHNICAL DRAWINGS

Front

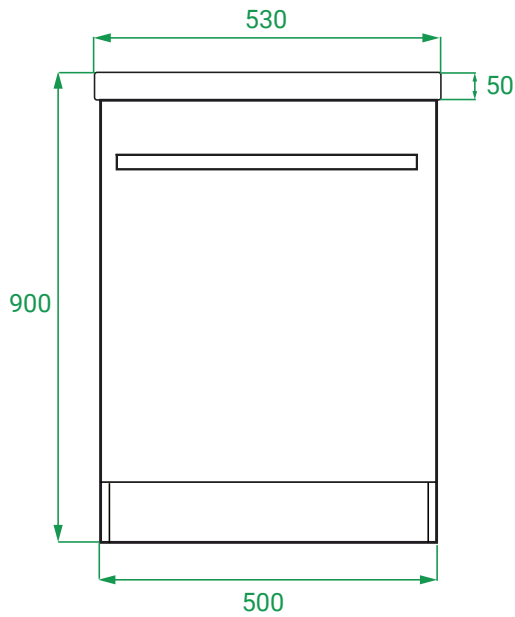

Side

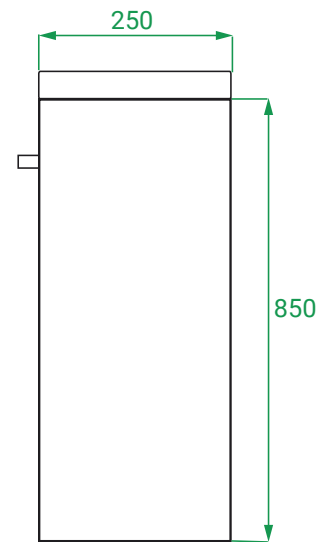

Basin Top

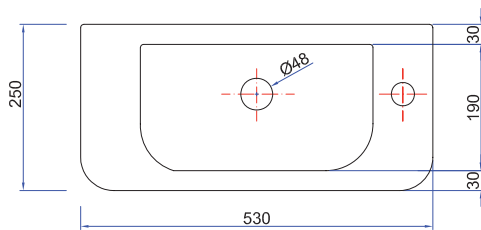

Basin Side

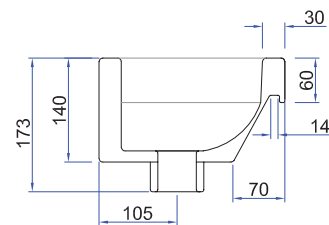

Basin Front

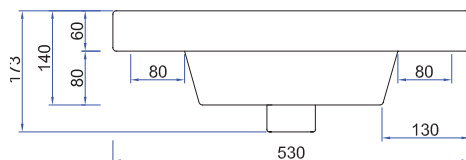

## NOTES

See our website for product prices. Drawing indicates the technical measurement only and is not a reflection of how the product will look. Sizes are nominal only. All drawings in millimeters. Drawings not to scale. 2023.