

DESCRIPTION

Sonit Freestanding Clearstone Bath

PRODUCT CODE

N8ECS



FEATURES

- Dimensions - L1690 x H585 x W700 mm
- Weight - 74kg
- Displaced Capacity - 179 litres*
- Made of ClearStone - an advanced, new material bonded together with milled sedimentary stone and high performance aluminum and titanium filler base. The result creates a hard wearing, scratch resistant surface with exceptional performance engineered to last a lifetime.
- High gloss surface in a brilliant white colour.
- Delicate rims and softer profiles.
- No overflow. Template for overflow drilling is attached to the bath for easy installation on site.
- Included bath waste (CW2).

TECHNICAL DRAWINGS

Top

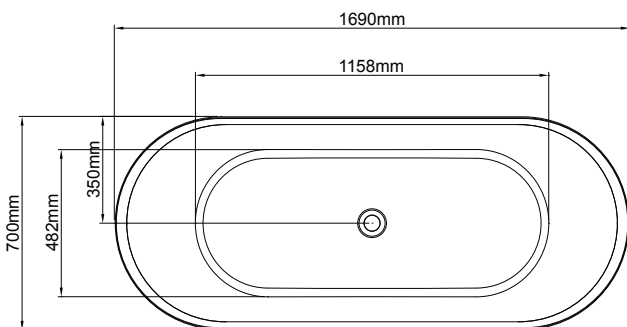

Front

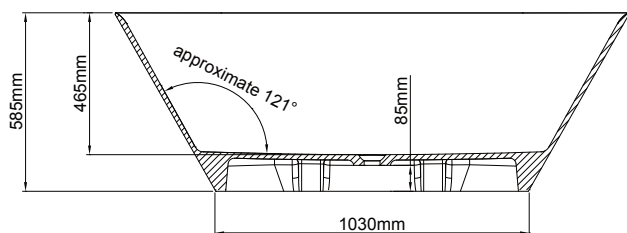

Side Section

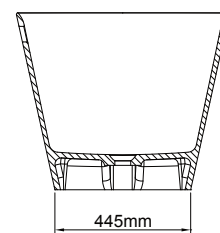

NOTES

*Volume of water contained in the bath if filled to the overflow less 70 litres to allow for an average person in the bath. Not suitable for rim-mounted taps. Suction mats not to be used on this bath. Tapware and accessories not included. Drawing indicates the technical measurement only and is not a reflection of how the unit will look. Sizes are nominal only. All drawings in millimeters. Drawings not to scale. September 2019.