

# Mike Pro Double Shower Mixer /



## DESCRIPTION

Mike Pro Double Shower Mixer

## PRODUCT CODE

PROTHERM



## FEATURES

- Dimensions - W120 x H215 x D139 mm
- Twin Lever
- Wall-Mounted
- Shower Thermostatic Valve
- Maintains selected temperature within +/-1.5°C
- Thermo ceramic disc cartridge
- Minimum pressure 0.2 Bar LP
- Suitable for low or mains pressure

## TECHNICAL SPECIFICATIONS

Front View

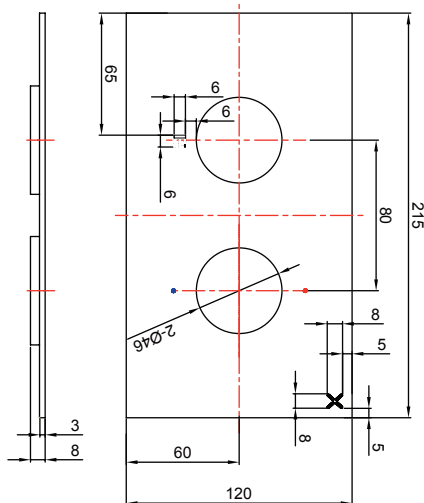

Side View

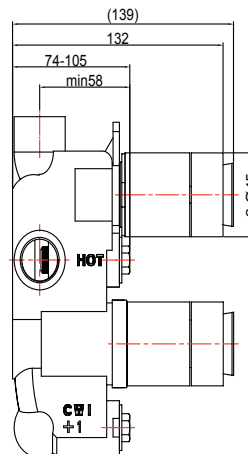

Cross Section Front View

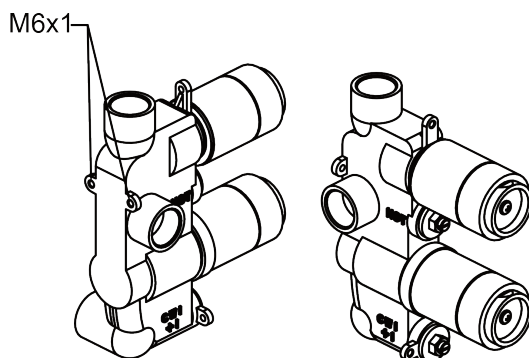
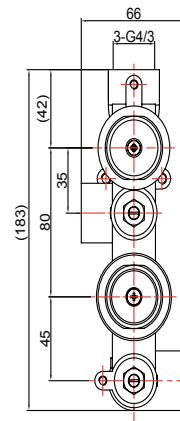

## Note:

For each part of the accessory, the dimension tolerance should be followed the list below.

0 ~ 100	101 ~ 200	201 ~ 400	≥ 401
±1	±2	±3	±5

For the finished assembly, the dimension tolerance should be followed the list below.

0 ~ 300	≥ 301
±2	±5

## NOTES

- Tapware & accessories not included • No tap holes or overflow. • Please use a contoured waste with all basins. Requires an unslotted waste.
- Drawing indicates the technical measurement only and is not a reflection of how the product will look. Sizes nominal only. Drawings in millimetres. Not to scale. • Tap holes do not come pre-drilled – this is the responsibility of the installer, and can be cut with a hole saw, jigsaw or router. March 2021.