

CLEAR 6 INFOLD /

vcbc

DESCRIPTION

Clear 6 Infold Shower Package - 900mm

PRODUCT CODE

LI90

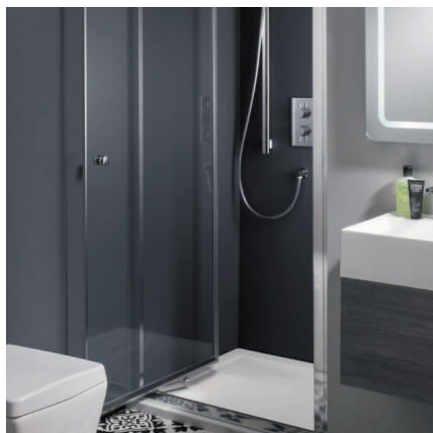

FEATURES

- Dimensions - W910 x H1985 x D910mm
- Package includes shower door, side panel, 2-sided acrylic wall liner, shower tray with 2 premoulded upstands (Z1409), easy clean waste and glue pack.
- Door Entry - W695mm
- Satin silver chrome finish frame with clear glass.
- 30mm adjustment for easy fitting per panel. Adjustment: 860 – 890mm.
- Infold door with reversible design for left or right opening.
- 6mm toughened safety glass with 3M Ultimate Glass Protection System.
- Power Showerproof - all shower screens and panels are laminated and treated to ensure the screen will not go damp or discolour, provides daily easy cleaning.

TECHNICAL DRAWINGS

Shower Door

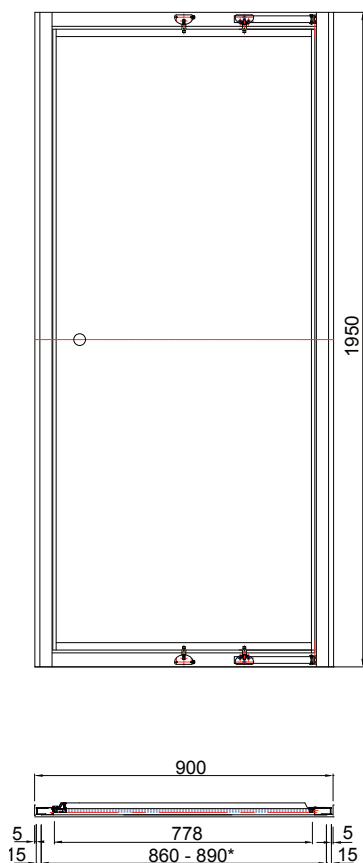

Top Section

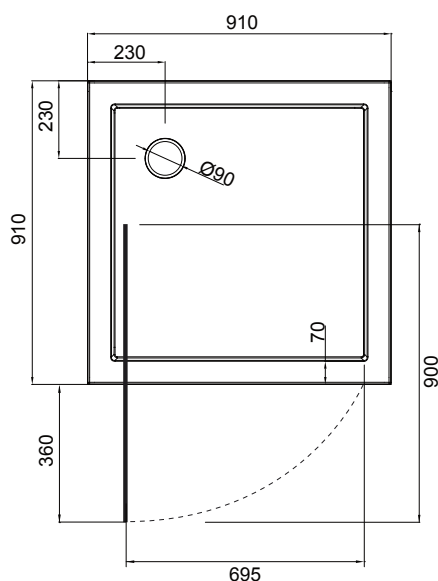

Side Panel

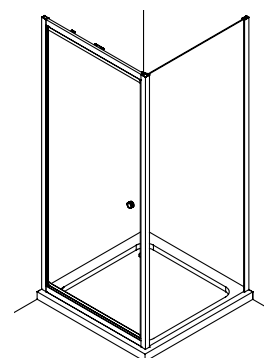
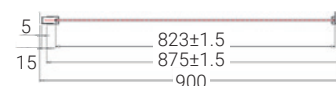

NOTES

Acrylic wall liners are custom-made and are supplied after wall-to-wall GIB measurements have been provided. Drawing indicates the technical measurement only and is not a reflection of how the unit will look. Sizes are nominal only, allow ± 10 mm for all measurements. All drawings in millimeters. Drawings not to scale. March 2022.