

Central Shower

vcbc

DESCRIPTION

Central Shower Double Slider Door - 1800mm (Limited Stock)

PRODUCT CODE

16.D.12446



FEATURES

- Dimensions - W1760 x H1950mm
- Door Entry - W703mm
- Signature roller system using smooth gliding wheels.
- Polished chrome finish fittings.
- 8mm clear toughened safety glass with 3M Ultimate Glass Protection System.
- Powershower proof – Shower screens have been carefully developed and tested to ensure they can withstand the optimum performance of a power shower.
- 30mm adjustment for easy fitting.
- Door can be fitted by itself only (alcove shower).

TECHNICAL DRAWINGS

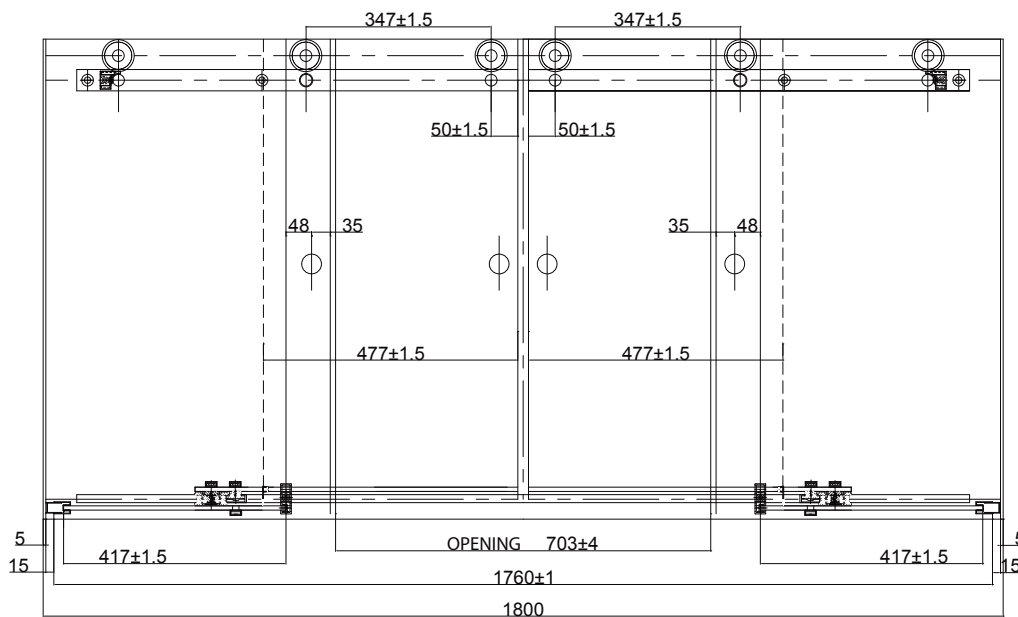

30mm adjustment for easy fitting per panel

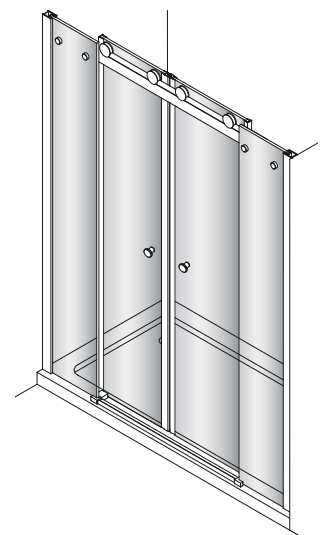

Double Sliding Door
(central opening)

NOTES

Excludes tap ware & accessories. If a liner or upstands are required – these are custom-made and are supplied after wall-to-wall GIB measurements have been provided. Drawing indicates the technical measurement only and is not a reflection of how the unit will look. Sizes are nominal only. All drawings in millimeters. Drawings not to scale. October 2019.